

INNER RINGS

- Inner Rings for Shell Type Needle Roller Bearings
- Inner Rings for General Usage

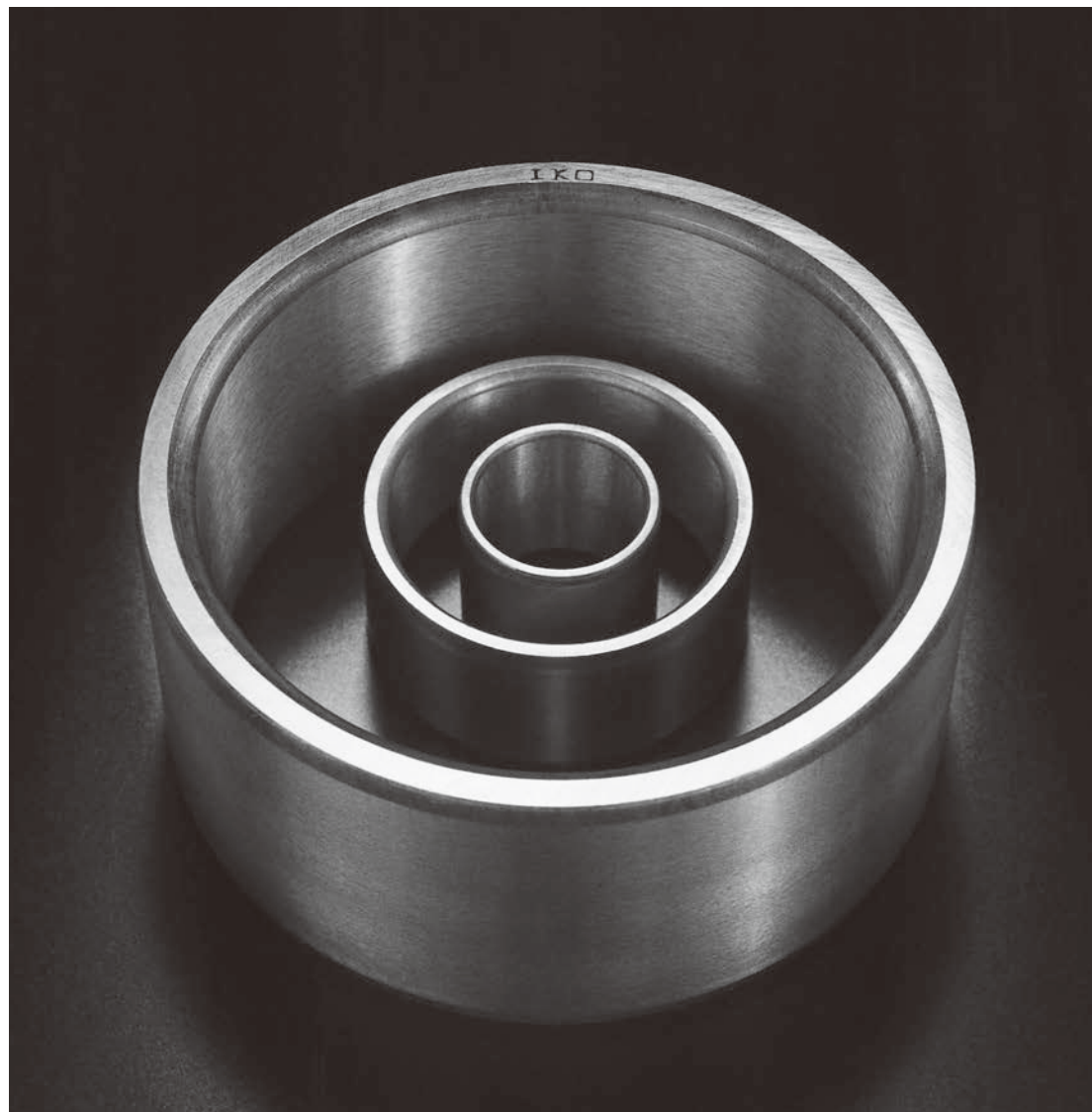

Structure and Features

IKO Inner Rings are heat-treated and finished by grinding to a high degree of accuracy. In the case of needle roller bearings, normally, the shafts are heat-treated and finished by grinding, and used as the raceway surfaces. However, when it is impossible to make shaft surfaces according to the specified surface hardness or surface roughness, inner rings are used.

Inner rings include those for Shell Type Needle Roller Bearings and those for general use and are available in a variety of dimensions. When shafts move axially or seals are used adjacent to bearings, wide inner rings can be selected.

Inner rings can also be used economically as bushings without requiring any additional machining.

Types

For Inner Rings, the types shown in Table 1 are available.

Table 1.1 Inner Rings for Shell Type Needle Roller Bearings

Series		Model codes of assembled bearings
Metric series	IRT	TA...Z, TLA...Z TAM, TLAM, YT, YTL
Inch series	IRB	BA...Z, BHA...Z BAM, BHAM, YB, YBH

Remark For Inner Rings for Shell Type Needle Roller Bearings with Seal, please consult **IKO**.

Table 1.2 Inner Rings for General Usage

Series		Model codes of assembled bearings
Metric series	LRT	RNA 49, RNA 69 RNA 48, TAF, TR RNAF, NAX, NBX
	LRTZ	RNA 49...UU, RNA 69...UU GTR
Inch series	LRB	BR
	LRBZ...B	BR...UU

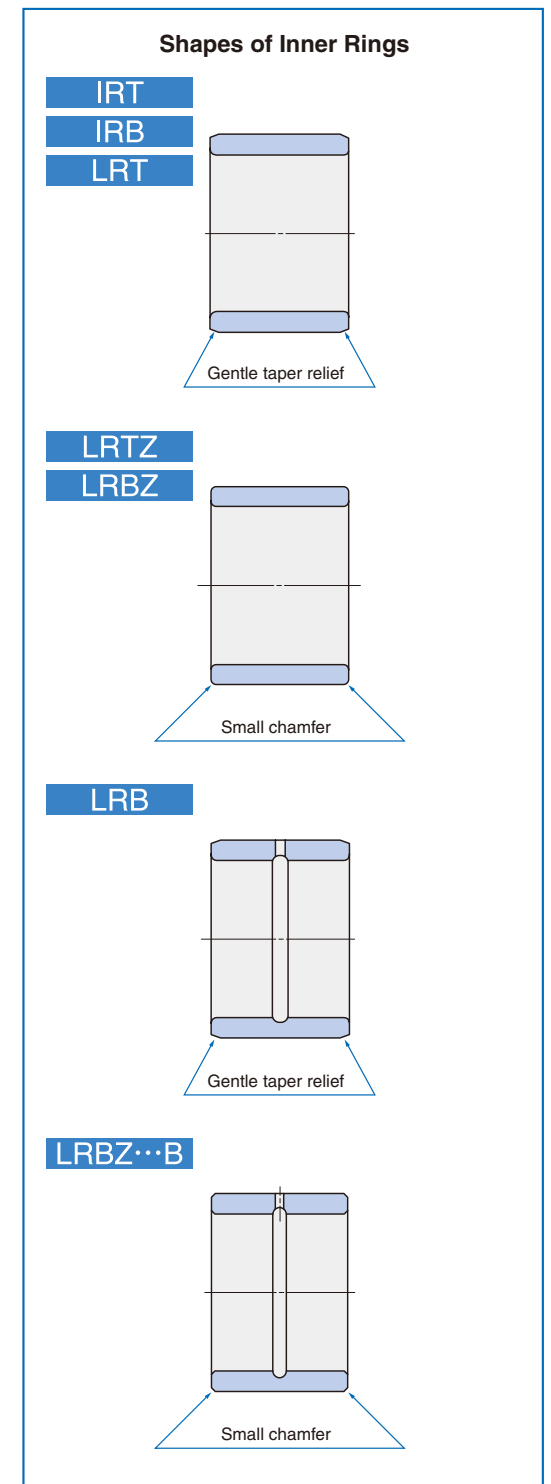

H

IRT
IRB
LRT
LRB

Identification number

The identification number of Inner Rings consists of a model code and dimensions. An example is shown below.

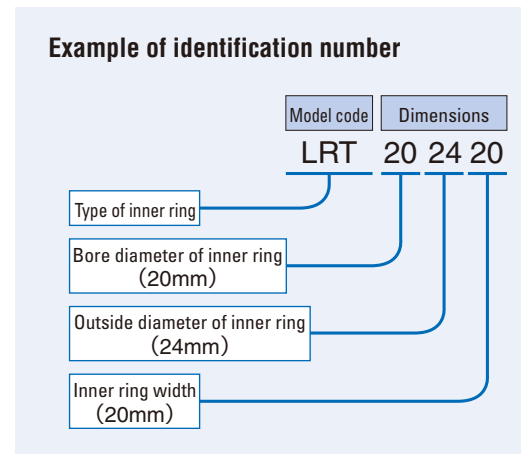

Accuracy

Dimensional accuracy of Inner Rings is based on Table 2. Inner Rings for Shell Type Needle Roller Bearings are manufactured so that exact radial internal clearances can be obtained when assembled with Shell Type Needle Roller Bearings. Inner Rings for General Usage produce CN clearance when used in the assembled bearings shown in Table 1.2. LRB and LRBZ...B models produce the radial internal clearances shown in Table 4 on page D5.

When clearances other than CN clearance or accuracy other than Class 0 are required, please consult **IKO**.

Table 2 Tolerances for inner ring

Model code	Tolerance
IRT LRT, LRTZ	JIS Class 0 (See the table 12, page A31)
IRB	Based on Table 3
LRB LRBZ...B	Based on Table 4

Remark Tolerances of outside diameter of inner ring are based on Table 5.

Table 3 Tolerances of IRB unit: μm

Nominal inside diameter of inner ring d mm	Δ_{dmp} Single plane mean bore diameter deviation	Δ_{Bs} Deviation of a single inner ring width		K_{ia} Radial runout of assembled bearing inner ring
		High	Low	
Over	Incl.	High	Low	Max.
2.5	10	0	-13	10
10	18	0	-13	10
18	30	0	-13	13
30	50	0	-13	15
50	80	0	-13	20

Table 4 Tolerances of LRB,LRBZ...B unit: μm

Nominal inside diameter of inner ring d mm	Δ_{dmp} Single plane mean bore diameter deviation	Δ_{Bs} Deviation of a single inner ring width		K_{ia} Radial runout of assembled bearing inner ring
		High	Low	
Over	Incl.	High	Low	Max.
-	19.050	0	-10	10
19.050	30.162	0	-13	13
30.162	50.800	0	-13	15
50.800	82.550	0	-15	20
82.550	120.650	0	-20	25

Table 6 Tolerances of outside diameters for LRT and LRTZ (When the clearance is CN clearance)

d Bore diameter of inner ring mm	F Outside diameter of inner ring mm																								d Bore diameter of inner ring mm	
	F Outside diameter of inner ring mm												F Outside diameter of inner ring mm													
	3 < F ≤ 6	6 < F ≤ 10	10 < F ≤ 18	18 < F ≤ 30	30 < F ≤ 50	50 < F ≤ 80	80 < F ≤ 120	120 < F ≤ 180	180 < F ≤ 250	250 < F ≤ 315	315 < F ≤ 400	400 < F ≤ 500	Over	Incl.												
Over	Incl.	High	Low	High	Low	High	Low	High	Low	High	Low	High	Low	High	Low	High	Low	High	Low	High	Low	High	Low	Over	Incl.	
-	24	-10	-27	-7	-23	-4	-18	0	-12																	24
24	30							0	-12	+5	-4															30
30	40							0	-12	0	-9															40
40	50									-5	-19															50
50	65											0	-11													65
65	80											-10	-21													80
80	100											-10	-26													100
100	120																									120
120	140																									140
140	160																									160
160	180																									180
180	200																									200
200	225																									225
225	250																									250
250	280																									280
280	315																									315
315	355																									355
355	400																									400
400	450																									450
450	500																									500

Table 5 Tolerances of outside diameter of inner ring unit: μm

Model code	Tolerance
IRT	g5
IRB	0 ~ -13
LRT, LRTZ	Based on Table 6
LRB, LRBZ...B	Based on Table 7

Table 7 Tolerances of outside diameters of LRB and LRBZ...B unit: μm

Nominal outside diameter of inner ring mm	Tolerance			
	Over	Incl.	High	Low
-	18.034	25.908	-13	-23
18.034	25.908	30.226	-18	-30
25.908	30.226	35.052	-23	-36
30.226	35.052	50.038	-23	-38
35.052	50.038	80.010	-25	-41
50.038	80.010	100.076	-28	-46
80.010	100.076	102.108	-32	-56
100.076	102.108		-37	-66

Fit

The recommended fits between Inner Rings and shafts are shown in Table 22 on page A42.

Oil Hole

The number of oil holes is shown in Table 8. When Inner Rings with an oil hole are especially required for a model without an oil hole, attach an "OH" to the end of the identification number when ordering.

Example: LRT 202420 OH
For Inner Rings with multiple oil holes, please consult **IKO**.

Table 8 Number of oil holes

Bearing type	Bore diameter of inner ring d mm	Metric series	Inch series	Number of oil holes	
					For Shell Type Needle Roller Bearings
For General Usage		LRT	0		
		LRTZ	0		
		LRB	$d \leq 76.200$	1	
			$76.200 < d$	2	
		LRBZ...B	1		

Remark Inner rings with an oil hole are provided with an oil groove.

INNER RINGS

Inner Rings for Shell Type Needle Roller Bearings

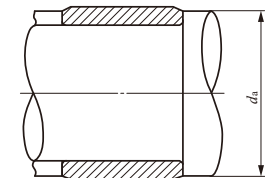
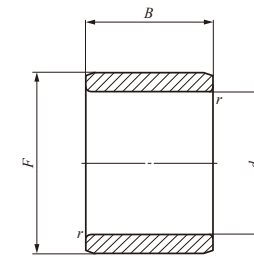

IRT

Shaft dia. 7 – 17mm

Shaft dia. mm	Identification number	Mass (Ref.) g	Boundary dimensions mm				Standard mounting dimension mm		Assembled bearings		
			<i>d</i>	<i>F</i>	<i>B</i>	<i>r_{s min}</i> ⁽¹⁾	Min.	Max.	TA ... Z (TAM)	TLA ... Z (TLAM)	YT YTL
7	IRT 710	3.2	7	10	10.5	0.3	9	9.7	TA 1010Z	TLA 1010Z	—
	IRT 712	3.9	7	10	12.5	0.3	9	9.7	TA 1012Z	TLA 1012Z	—
	IRT 715	4.8	7	10	15.5	0.3	9	9.7	TA 1015Z	TLA 1015Z	—
8	IRT 810	5.1	8	12	10.5	0.3	10	11	—	TLA 1210Z	YTL 1210
	IRT 812	6	8	12	12.5	0.3	10	11	TA 1212Z	TLA 1212Z	YT 1212
	IRT 815	7.5	8	12	15.5	0.3	10	11	TA 1215Z	—	—
10	IRT 1012	5.2	10	13	12.5	0.3	12	12.7	—	TLA 1312Z	—
	IRT 1012-2	7.2	10	14	12.5	0.3	12	13	—	TLA 1412Z	—
	IRT 1016-2	9.6	10	14	16.5	0.3	12	13	TA 1416Z	TLA 1416Z	—
	IRT 1020-2	11.9	10	14	20.5	0.3	12	13	TA 1420Z	—	—
	IRT 1010-1	7.9	10	15	10.5	0.3	12	14	TA 1510Z	—	—
	IRT 1012-1	9.4	10	15	12.5	0.3	12	14	TA 1512Z	TLA 1512Z	—
	IRT 1015-1	11.7	10	15	15.5	0.3	12	14	TA 1515Z	—	—
	IRT 1020-1	15.5	10	15	20.5	0.3	12	14	TA 1520Z	—	—
	IRT 1025-1	19.3	10	15	25.5	0.3	12	14	TA 1525Z	—	—
12	IRT 1212	6.1	12	15	12.5	0.3	14	14.5	TA 1512Z	TLA 1512Z	—
	IRT 1216	8.1	12	15	16.5	0.3	14	14.5	—	TLA 1516Z	—
	IRT 1222	11	12	15	22.5	0.3	14	14.5	—	TLA 1522Z	—
	IRT 1212-1	8.5	12	16	12.5	0.3	14	15	—	TLA 1612Z	—
	IRT 1216-1	11.2	12	16	16.5	0.3	14	15	TA 1616Z	TLA 1616Z	—
	IRT 1220-1	13.9	12	16	20.5	0.3	14	15	TA 1620Z	—	—
	IRT 1222-1	15.2	12	16	22.5	0.3	14	15	—	TLA 1622Z	—
	IRT 1215-2	13.6	12	17	15.5	0.3	14	16	TA 1715Z	—	YT 1715
	IRT 1220-2	18	12	17	20.5	0.3	14	16	TA 1720Z	—	—
	IRT 1225-2	22.5	12	17	25.5	0.3	14	16	TA 1725Z	—	YT 1725
15	IRT 1512	7.5	15	18	12.5	0.3	17	17.5	—	TLA 1812Z	—
	IRT 1513	8.1	15	18	13.5	0.3	17	17.5	TA 1813Z	—	—

Note⁽¹⁾ Minimum allowable value of chamfer dimension *r*
 Remark No oil hole is provided.

Shaft dia. mm	Identification number	Mass (Ref.) g	Boundary dimensions mm				Standard mounting dimension mm		Assembled bearings		
			<i>d</i>	<i>F</i>	<i>B</i>	<i>r_{s min}</i> ⁽¹⁾	Min.	Max.	TA ... Z (TAM)	TLA ... Z (TLAM)	YT YTL
15	IRT 1515	9.3	15	18	15.5	0.3	17	17.5	TA 1815Z	—	—
	IRT 1516	9.9	15	18	16.5	0.3	17	17.5	—	TLA 1816Z	—
	IRT 1517	10.5	15	18	17.5	0.3	17	17.5	TA 1817Z	—	—
	IRT 1519	11.7	15	18	19.5	0.3	17	17.5	TA 1819Z	—	—
	IRT 1520	12.3	15	18	20.5	0.3	17	17.5	TA 1820Z	—	—
	IRT 1525	15.2	15	18	25.5	0.3	17	17.5	TA 1825Z	—	—
	IRT 1516-1	13.6	15	19	16.5	0.3	17	18	TA 1916Z	—	—
	IRT 1520-1	16.8	15	19	20.5	0.3	17	18	TA 1920Z	—	—
	IRT 1515-2	16.4	15	20	15.5	0.3	17	19	TA 2015Z	—	YT 2015
	IRT 1520-2	21.5	15	20	20.5	0.3	17	19	TA 2020Z	TLA 2020Z	YT 202820
	IRT 1525-2	27	15	20	25.5	0.3	17	19	TA 2025Z	—	YT 2025
	IRT 1530-2	32	15	20	30.5	0.3	17	19	TA 2030Z	TLA 2030Z	—
17	IRT 1716	11.1	17	20	16.5	0.3	19	19.5	—	TLA 2016Z	—
	IRT 1720	13.7	17	20	20.5	0.3	19	19.5	TA 2020Z	TLA 2020Z	YT 202820
	IRT 1730	20.5	17	20	30.5	0.3	19	19.5	TA 202820Z	—	—
	IRT 1716-1	15.1	17	21	16.5	0.3	19	20	TA 2030Z	TLA 2030Z	—
	IRT 1720-1	18.8	17	21	20.5	0.3	19	20	TA 2116Z	—	YT 2116
	IRT 1710-2	12.4	17	22	10.5	0.3	19	21	TA 2120Z	—	YT 2120
	IRT 1715-2	18.3	17	22	15.5	0.3	19	21	TA 2210Z	—	—
	IRT 1716-2	19.4	17	22	16.5	0.3	19	21	TA 2215Z	—	—
	IRT 1720-2	24	17	22	20.5	0.3	19	21	TA 223016Z	TLA 2216Z	YT 223016
	IRT 1725-2	30	17	22	25.5	0.3	19	21	TA 2220Z	TLA 2220Z	YT 223020
	IRT 1730-2	36	17	22	30.5	0.3	19	21	TA 223020Z	—	—
	IRT 1725Z	—	—	—	—	—	—	—	TA 2225Z	—	—
	IRT 1730Z	—	—	—	—	—	—	—	TA 2230Z	—	—

Note⁽¹⁾ Minimum allowable value of chamfer dimension *r*
 Remark No oil hole is provided.

H

IRT
IRB
LRT
LRB

INNER RINGS

Inner Rings for Shell Type Needle Roller Bearings

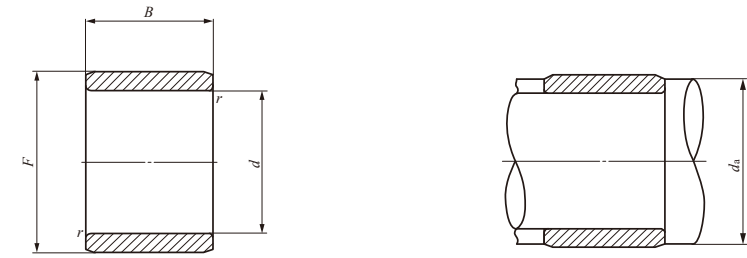

IRT

Shaft dia. 20 – 45mm

Shaft dia. mm	Identification number	Mass (Ref.) g	Boundary dimensions mm				Standard mounting dimension mm		Assembled bearings		
			d	F	B	⁽¹⁾ r _{s min}	Min.	Max.	TA ... Z (TAM)	TLA ... Z (TLAM)	YT YTL
20	IRT 2016	17.5	20	24	16.5	0.3	22	23	TA 243216Z	—	YT 243216
	IRT 2020	22	20	24	20.5	0.3	22	23	TA 2420Z	—	YT 243220
									TA 243220Z	—	
	IRT 2028	30.5	20	24	28.5	0.3	22	23	TA 2428Z	—	YT 2428
	IRT 2010-1	14.3	20	25	10.5	0.3	22	24	TA 2510Z	—	YT 2510
	IRT 2015-1	21	20	25	15.5	0.3	22	24	TA 2515Z	—	YT 2515
	IRT 2020-1	28	20	25	20.5	0.3	22	24	TA 2520Z	TLA 2520Z	YT 2520
	IRT 2025-1	34.5	20	25	25.5	0.3	22	24	TA 2525Z	—	YT 2525
	IRT 2026-1	36	20	25	26.5	0.3	22	24	—	TLA 2526Z	YTL 2526
	IRT 2030-1	41.5	20	25	30.5	0.3	22	24	TA 2530Z	—	—
IRT 2038-1	52.5	20	25	38.5	0.3	22	24	—	TLAW 2538Z	—	
22	IRT 2216	19.1	22	26	16.5	0.3	24	25	TA 2616Z	—	YT 2616
	IRT 2220	24	22	26	20.5	0.3	24	25	TA 2620Z	—	YT 2620
	IRT 2220-1	37	22	28	20.5	0.3	24	27	TA 2820Z	TLA 2820Z	YT 2820
	IRT 2230-1	55.5	22	28	30.5	0.3	24	27	TA 2830Z	—	—
25	IRT 2520	26.5	25	29	20.5	0.3	27	28	TA 2920Z	—	YT 2920
	IRT 2530	40	25	29	30.5	0.3	27	28	TA 2930Z	—	—
	IRT 2515-1	25.5	25	30	15.5	0.3	27	29	TA 3015Z	—	—
	IRT 2520-1	34	25	30	20.5	0.3	27	29	TA 3020Z	TLA 3020Z	—
	IRT 2525-1	42.5	25	30	25.5	0.3	27	29	TA 3025Z	—	—
	IRT 2526-1	44	25	30	26.5	0.3	27	29	—	TLA 3026Z	—
	IRT 2530-1	50.5	25	30	30.5	0.3	27	29	TA 3030Z	—	—
	IRT 2538-1	64	25	30	38.5	0.3	27	29	—	TLAW 3038Z	—
28	IRT 2820	29.5	28	32	20.5	0.3	30	31	TA 3220Z	—	YT 3220
	IRT 2830	44	28	32	30.5	0.3	30	31	TA 3230Z	—	—
30	IRT 3012	24.5	30	35	12.5	0.6	34	34.5	TA 3512Z	TLA 3512Z	—
	IRT 3015	30.5	30	35	15.5	0.6	34	34.5	TA 3515Z	—	—

Note⁽¹⁾ Minimum allowable value of chamfer dimension r
Remark No oil hole is provided.

Shaft dia. mm	Identification number	Mass (Ref.) g	Boundary dimensions mm				Standard mounting dimension mm		Assembled bearings		
			d	F	B	⁽¹⁾ r _{s min}	Min.	Max.	TA ... Z (TAM)	TLA ... Z (TLAM)	YT YTL
30	IRT 3020	40	30	35	20.5	0.6	34	34.5	TA 3520Z	TLA 3520Z	—
	IRT 3025	50	30	35	25.5	0.6	34	34.5	TA 3525Z	—	—
	IRT 3030	60	30	35	30.5	0.6	34	34.5	TA 3530Z	—	—
32	IRT 3220	42.5	32	37	20.5	0.6	36	36.5	TA 3720Z	—	YT 3720
	IRT 3230	63.5	32	37	30.5	0.6	36	36.5	TA 3730Z	—	—
	IRT 3215-1	39.5	32	38	15.5	0.6	36	37	TA 3815Z	—	—
	IRT 3220-1	52	32	38	20.5	0.6	36	37	TA 3820Z	—	—
	IRT 3225-1	64.5	32	38	25.5	0.6	36	37	TA 3825Z	—	—
	IRT 3230-1	77.5	32	38	30.5	0.6	36	37	TA 3830Z	—	—
	IRT 3245-1	115	32	38	45.5	0.6	36	37	TAW 3845Z	—	—
35	IRT 3515	35	35	40	15.5	0.6	39	39.5	TA 4015Z	—	YT 4015
	IRT 3520	46.5	35	40	20.5	0.6	39	39.5	TA 4020Z	TLA 4020Z	—
	IRT 3525	58	35	40	25.5	0.6	39	39.5	TA 4025Z	—	YT 4025
	IRT 3530	69	35	40	30.5	0.6	39	39.5	TA 4030Z	—	—
	IRT 3540	91.5	35	40	40.5	0.6	39	39.5	TA 4040Z	—	—
40	IRT 4020	52.5	40	45	20.5	0.6	44	45.5	TA 4520Z	TLA 4520Z	YT 4520
	IRT 4025	65.5	40	45	25.5	0.6	44	45.5	TA 4525Z	—	YT 4525
	IRT 4030	78.5	40	45	30.5	0.6	44	45.5	TA 4530Z	—	—
	IRT 4040	104	40	45	40.5	0.6	44	45.5	TA 4540Z	—	—
45	IRT 4512	36	45	50	12.5	0.6	49	49.5	TA 5012Z	—	—
	IRT 4515	44.5	45	50	15.5	0.6	49	49.5	TA 5015Z	—	—
	IRT 4520	59	45	50	20.5	0.6	49	49.5	TA 5020Z	TLA 5020Z	—
	IRT 4525	73	45	50	25.5	0.6	49	49.5	TA 5025Z	TLA 5025Z	—
	IRT 4530	87.5	45	50	30.5	0.6	49	49.5	TA 5030Z	—	—
	IRT 4540	116	45	50	40.5	0.6	49	49.5	TA 5040Z	—	—
IRT 4545	131	45	50	45.5	0.6	49	49.5	TAW 5045Z	—	—	

Note⁽¹⁾ Minimum allowable value of chamfer dimension r
Remark No oil hole is provided.

Inner Rings for Shell Type Needle Roller Bearings

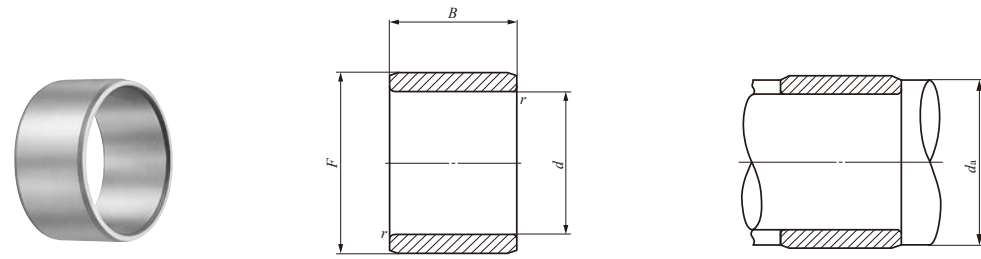

IRT

Shaft dia. 50 – 60mm

Shaft dia. mm	Identification number	Mass (Ref.) g	Boundary dimensions mm				Standard mounting dimension mm		Assembled bearings		
			d	F	B	⁽¹⁾ r _{s min}	Min.	Max.	TA ... Z (TAM)	TLA ... Z (TLAM)	YT YTL
50	IRT 5020-1	65	50	55	20.5	0.6	54	54.5	TA 5520Z	TLA 5520Z	—
	IRT 5025-1	81	50	55	25.5	0.6	54	54.5	TA 5525Z	TLA 5525Z	—
	IRT 5030-1	96.5	50	55	30.5	0.6	54	54.5	TA 5530Z	—	—
	IRT 5040-1	128	50	55	40.5	0.6	54	54.5	TA 5540Z	—	—
	IRT 5045-1	144	50	55	45.5	0.6	54	54.5	TAW 5545Z	—	—
	IRT 5050-1	160	50	55	50.5	0.6	54	54.5	TAW 5550Z	—	—
	IRT 5025	169	50	60	25.5	1.5	58	59	TA 6025Z	—	—
	IRT 5030	205	50	60	30.5	1.5	58	59	TA 6030Z	—	—
	IRT 5040	270	50	60	40.5	1.5	58	59	TA 6040Z	—	—
	IRT 5045	300	50	60	45.5	1.5	58	59	TAW 6045Z	—	—
IRT 5050	335	50	60	50.5	1.5	58	59	TAW 6050Z	—	—	
52	IRT 5212	86	52	62	12.5	1.5	60	60.5	TA 6212Z	—	—
55	IRT 5525	185	55	65	25.5	1.5	63	63.5	TA 6525Z	—	—
	IRT 5530	220	55	65	30.5	1.5	63	63.5	TA 6530Z	—	—
	IRT 5545	330	55	65	45.5	1.5	63	63.5	TAW 6545Z	—	—
	IRT 5550	365	55	65	50.5	1.5	63	63.5	TAW 6550Z	—	—
60	IRT 6025	200	60	70	25.5	1.5	68	68.5	TA 7025Z	—	—
	IRT 6030	240	60	70	30.5	1.5	68	68.5	TA 7030Z	—	—
	IRT 6040	320	60	70	40.5	1.5	68	68.5	TA 7040Z	—	—
	IRT 6050	395	60	70	50.5	1.5	68	68.5	TAW 7050Z	—	—

Note⁽¹⁾ Minimum allowable value of chamfer dimension r
Remark No oil hole is provided.

Inner Rings for Shell Type Needle Roller Bearings **Inch Series**

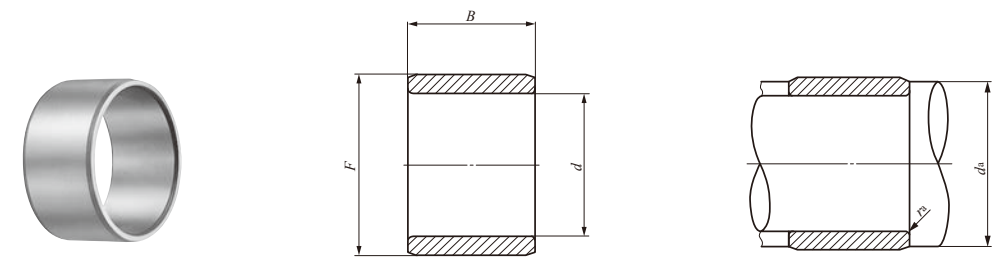

IRB

Shaft dia. 7.938 – 15.875mm

Shaft dia. mm (inch)	Identification number	Mass (Ref.) g	Boundary dimensions mm(inch)			Standard mounting dimensions mm ⁽¹⁾			Assembled bearings		
			d	F	B	Min.	Max.	r _{as max} Max.	BA ... Z (BAM)	BHA ... Z (BHAM)	YB YBH
7.938 (5/16)	IRB 58	8	7.938 (5/16)	12.700 (1/2)	13.08	11.3	11.7	0.3	BA 88Z	BHA 88Z	YB 88
9.525 (3/8)	IRB 68	8.9	9.525 (3/8)	14.288 (9/16)	13.08	12.8	13.2	0.3	BA 98Z	BHA 98Z	YB 98
	IRB 68-1	12.6	9.525 (3/8)	15.875 (5/8)	13.08	12.8	14	0.3	BA 108Z	BHA 108Z	YB 108
11.112 (7/16)	IRB 612	13.2	9.525 (3/8)	14.288 (9/16)	19.43	12.8	13.2	0.3	BA 912Z	—	YB 912
	IRB 612-1	18.8	9.525 (3/8)	15.875 (5/8)	19.43	12.8	14	0.3	BA 1012Z	BHA 1012Z	YB 1012
12.700 (1/2)	IRB 78	10.1	11.112 (7/16)	15.875 (5/8)	13.08	14.4	14.8	0.3	BA 108Z	BHA 108Z	YB 108
	IRB 712	15	11.112 (7/16)	15.875 (5/8)	19.43	14.4	14.8	0.3	BA 1012Z	BHA 1012Z	YB 1012
	IRB 714	17.4	11.112 (7/16)	15.875 (5/8)	22.60	14.4	14.8	0.3	BA 1014Z	—	—
14.288 (9/16)	IRB 716	19.9	11.112 (7/16)	15.875 (5/8)	25.78	14.4	14.8	0.3	BA 1016Z	BHA 1016Z	—
	IRB 86	8.5	12.700 (1/2)	17.462 (11/16)	9.90	16.9	16.9	0.3	BA 116Z	—	—
	IRB 88	11.2	12.700 (1/2)	17.462 (11/16)	13.08	16.9	16.9	0.3	BA 118Z	BHA 118Z	—
	IRB 812	16.7	12.700 (1/2)	17.462 (11/16)	19.43	16.9	16.9	0.3	BA 1112Z	BHA 1112Z	YB 1112
	IRB 88-1	15.8	12.700 (1/2)	19.050 (3/4)	13.08	16.9	17.5	0.6	BA 128Z	—	YB 128
	IRB 810-1	19.6	12.700 (1/2)	19.050 (3/4)	16.25	16.9	17.5	0.6	BA 1210Z	—	YB 1210
	IRB 812-1	23.5	12.700 (1/2)	19.050 (3/4)	19.43	16.9	17.5	0.6	BA 1212Z	BHA 1212Z	YB 1212
15.875 (5/8)	IRB 814-1	27.5	12.700 (1/2)	19.050 (3/4)	22.60	16.9	17.5	0.6	BA 1214Z	—	—
	IRB 816-1	31	12.700 (1/2)	19.050 (3/4)	25.78	16.9	17.5	0.6	BA 1216Z	—	—
	IRB 98	17.3	14.288 (9/16)	20.638 (13/16)	13.08	19	19.6	0.6	BA 138Z	BHA 138Z	YB 138
	IRB 910	21.5	14.288 (9/16)	20.638 (13/16)	16.25	19	19.6	0.6	BA 1310Z	BHA 1310Z	YB 1310
	IRB 912	26	14.288 (9/16)	20.638 (13/16)	19.43	19	19.6	0.6	BA 1312Z	BHA 1312Z	YB 1312
15.875 (5/8)	IRB 914	30	14.288 (9/16)	20.638 (13/16)	22.60	19	19.6	0.6	BA 1314Z	—	—
	IRB 916	34.5	14.288 (9/16)	20.638 (13/16)	25.78	19	19.6	0.6	BA 1316Z	—	—
	IRB 920	43	14.288 (9/16)	20.638 (13/16)	32.13	19	19.6	0.6	BA 1320Z	—	—
	IRB 106	14.5	15.875 (5/8)	22.225 (7/8)	9.90	20.7	21.2	0.6	BA 146Z	—	—
15.875 (5/8)	IRB 108	18.9	15.875 (5/8)	22.225 (7/8)	13.08	20.7	21.2	0.6	BA 148Z	—	YB 148
	IRB 1012	28	15.875 (5/8)	22.225 (7/8)	19.43	20.7	21.2	0.6	BA 1412Z	BHA 1412Z	YB 1412

Note⁽¹⁾ Maximum allowable fillet corner radius of shaft
Remark No oil hole is provided.

INNER RINGS

Inner Rings for Shell Type Needle Roller Bearings Inch Series

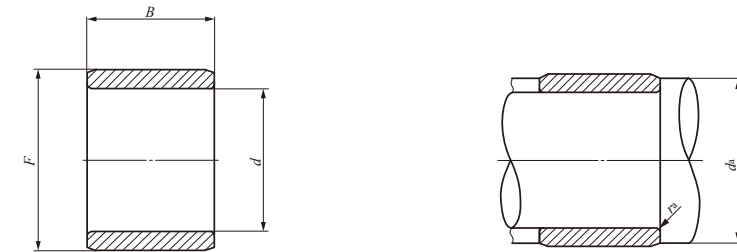

IRB

Shaft dia. 15.875 – 63.500mm

Shaft dia. mm (inch)	Identification number	Mass (Ref.) g	Boundary dimensions mm(inch)			Standard mounting dimensions mm ⁽¹⁾			Assembled bearings		
			d	F	B	d _a Min.	d _a Max.	r _{as max} Max.	BA...Z (BAM)	BHA...Z (BHAM)	YB YBH
15.875 (5/8)	IRB 1014	33	15.875 (5/8)	22.225 (7/8)	22.60	20.7	21.2	0.6	BA 1414Z	—	—
	IRB 1016	37.5	15.875 (5/8)	22.225 (7/8)	25.78	20.7	21.2	0.6	BA 1416Z	BHA 1416Z	YB 1416
	IRB 1022	51.5	15.875 (5/8)	22.225 (7/8)	35.30	20.7	21.2	0.6	BA 1422Z	—	—
17.462 (11/16)	IRB 1110	25.5	17.462 (11/16)	23.812 (15/16)	16.25	22.3	22.8	0.6	BA 1510Z	—	—
	IRB 1116	40.5	17.462 (11/16)	23.812 (15/16)	25.78	22.3	22.8	0.6	BA 1516Z	—	—
19.050 (3/4)	IRB 128	22	19.050 (3/4)	25.400 (1)	13.08	23.9	24.4	0.6	BA 168Z	BHA 168Z	YB 168 YBH 168
	IRB 1212	33	19.050 (3/4)	25.400 (1)	19.43	23.9	24.4	0.6	BA 1612Z	BHA 1612Z	YB 1612 YBH 1612
	IRB 1214	38.5	19.050 (3/4)	25.400 (1)	22.60	23.9	24.4	0.6	BA 1614Z	BHA 1614Z	—
	IRB 1216	43.5	19.050 (3/4)	25.400 (1)	25.78	23.9	24.4	0.6	BA 1616Z	BHA 1616Z	YB 1616 YBH 1616
	IRB 1220	54.5	19.050 (3/4)	25.400 (1)	32.13	23.9	24.4	0.6	BA 1620Z	BHA 1620Z	—
20.638 (13/16)	IRB 1316	34	20.638 (13/16)	25.400 (1)	25.78	24.9	24.9	0.6	BA 1616Z	BHA 1616Z	YB 1616 YBH 1616
22.225 (7/8)	IRB 148	25	22.225 (7/8)	28.575 (1 1/8)	13.08	27	27.5	0.6	BA 188Z	—	YB 188
	IRB 1412	37.5	22.225 (7/8)	28.575 (1 1/8)	19.43	27	27.5	0.6	BA 1812Z	BHA 1812Z	YB 1812
	IRB 1416	50	22.225 (7/8)	28.575 (1 1/8)	25.78	27	27.5	0.6	BA 1816Z	BHA 1816Z	YB 1816
	IRB 1420	62.5	22.225 (7/8)	28.575 (1 1/8)	32.13	27	27.5	0.6	BA 1820Z	BHA 1820Z	—
25.400 (1)	IRB 168	28.5	25.400 (1)	31.750 (1 1/4)	13.08	30	30.7	0.6	BA 208Z	BHA 208Z	—
	IRB 1610	35.5	25.400 (1)	31.750 (1 1/4)	16.25	30	30.7	0.6	BA 2010Z	—	YB 2010
	IRB 1612	42.5	25.400 (1)	31.750 (1 1/4)	19.43	30	30.7	0.6	BA 2012Z	BHA 2012Z	YB 2012
	IRB 1616	56	25.400 (1)	31.750 (1 1/4)	25.78	30	30.7	0.6	BA 2016Z	BHA 2016Z	YB 2016
	IRB 1620	70	25.400 (1)	31.750 (1 1/4)	32.13	30	30.7	0.6	BA 2020Z	BHA 2020Z	—
	IRB 168-1	36.5	25.400 (1)	33.338 (1 5/16)	13.08	30	32.1	0.6	BA 218Z	—	—
	IRB 1610-1	45.5	25.400 (1)	33.338 (1 5/16)	16.25	30	32.1	0.6	BA 2110Z	—	—
	IRB 1612-1	54.5	25.400 (1)	33.338 (1 5/16)	19.43	30	32.1	0.6	BA 2112Z	—	—

Note(1) Maximum allowable fillet corner radius of shaft
Remark No oil hole is provided.

Shaft dia. mm (inch)	Identification number	Mass (Ref.) g	Boundary dimensions mm(inch)			Standard mounting dimensions mm ⁽¹⁾			Assembled bearings		
			d	F	B	d _a Min.	d _a Max.	r _{as max} Max.	BA...Z (BAM)	BHA...Z (BHAM)	YB YBH
28.575 (1 1/8)	IRB 188	31.5	28.575 (1 1/8)	34.925 (1 3/8)	13.08	33.2	33.9	0.6	BA 228Z	BHA 228Z	YB 228
	IRB 1812	47	28.575 (1 1/8)	34.925 (1 3/8)	19.43	33.2	33.9	0.6	BA 2212Z	BHA 2212Z	YB 2212
	IRB 1816	62.5	28.575 (1 1/8)	34.925 (1 3/8)	25.78	33.2	33.9	0.6	BA 2216Z	BHA 2216Z	—
31.750 (1 1/4)	IRB 1820	78	28.575 (1 1/8)	34.925 (1 3/8)	32.13	33.2	33.9	0.6	BA 2220Z	BHA 2220Z	YB 2220
	IRB 2010	43	31.750 (1 1/4)	38.100 (1 1/2)	16.25	37	37.1	0.6	BA 2410Z	—	—
34.925 (1 3/8)	IRB 2014	60	31.750 (1 1/4)	38.100 (1 1/2)	22.60	37	37.1	0.6	BA 2414Z	—	YB 2414
	IRB 2016	68.5	31.750 (1 1/4)	38.100 (1 1/2)	25.78	37	37.1	0.6	BA 2416Z	—	YB 2416
	IRB 2020	85.5	31.750 (1 1/4)	38.100 (1 1/2)	32.13	37	37.1	0.6	BA 2420Z	—	YB 2420
36.512 (1 7/16)	IRB 2210	47	34.925 (1 3/8)	41.275 (1 5/8)	16.25	40.2	40.2	0.6	BA 2610Z	—	YB 2610
	IRB 2220	93.5	34.925 (1 3/8)	41.275 (1 5/8)	32.13	40.2	40.2	0.6	BA 2620Z	—	—
38.100 (1 1/2)	IRB 2316	99	36.512 (1 7/16)	44.450 (1 3/4)	25.78	42.5	43.2	0.6	BA 2816Z	—	—
	IRB 2412	62	38.100 (1 1/2)	44.450 (1 3/4)	19.43	43.3	43.4	0.6	BA 2812Z	—	—
41.275 (1 5/8)	IRB 2416	81	38.100 (1 1/2)	44.450 (1 3/4)	25.78	43.3	43.4	0.6	BA 2816Z	—	YB 2816
	IRB 2424	121	38.100 (1 1/2)	44.450 (1 3/4)	38.48	43.3	43.4	0.6	BA 2824Z	BHA 2824Z	—
	IRB 248-1	64	38.100 (1 1/2)	47.625 (1 7/8)	13.08	44.5	45.5	1	BA 308Z	—	—
	IRB 2410-1	79.5	38.100 (1 1/2)	47.625 (1 7/8)	16.25	44.5	45.5	1	BA 3010Z	—	—
42.862 (1 11/16)	IRB 2616	136	41.275 (1 5/8)	50.800 (2)	25.78	47.5	48.5	1	BA 3216Z	—	—
	IRB 2628	235	41.275 (1 5/8)	50.800 (2)	44.83	47.5	48.5	1	BAW 3228Z	—	—
47.625 (1 7/8)	IRB 2720	146	42.862 (1 11/16)	50.800 (2)	32.13	48.5	49.5	0.6	BA 3220Z	—	—
	IRB 3016	100	47.625 (1 7/8)	53.975 (2 1/8)	25.78	52.9	52.9	0.6	BA 3416Z	—	—
57.150 (2 1/4)	IRB 3024	149	47.625 (1 7/8)	53.975 (2 1/8)	38.48	52.9	52.9	0.6	BA 3424Z	—	—
	IRB 3616	183	57.150 (2 1/4)	66.675 (2 5/8)	25.78	63.5	64.5	1	BA 4216Z	—	—
63.500 (2 1/2)	IRB 4016	131	63.500 (2 1/2)	69.850 (2 3/4)	25.78	68.7	68.8	0.6	BA 4416Z	—	—
	IRB 4020	164	63.500 (2 1/2)	69.850 (2 3/4)	32.13	68.7	68.8	0.6	BA 4420Z	—	—

Note(1) Maximum allowable fillet corner radius of shaft
Remark No oil hole is provided.



INNER RINGS

Inner Rings for General Usage

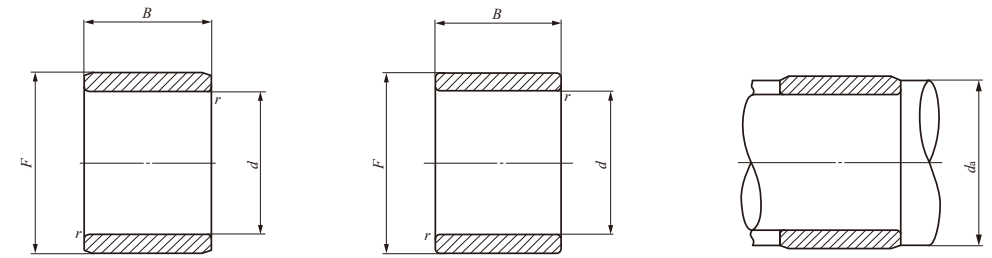

LRT

LRTZ

Shaft dia. 5 – 20mm

Shaft dia. mm	Identification number		Mass (Ref.) g	Boundary dimensions mm				Standard mounting dimension mm		Assembled bearings	
				d	F	B	r _{s min} ⁽¹⁾	d _a Min.	d _a Max.		
5	LRT 5710	—	1.4	5	7	10	0.15	6.2	6.7	RNA 495	
	LRT 5812	—	2.8	5	8	12	0.2	6.6	7.7	TAF 81512	
	LRT 5816	—	3.8	5	8	16	0.2	6.6	7.7	TAF 81516	
6	LRT 6810	—	1.7	6	8	10	0.15	7.2	7.7	RNA 496	
	LRT 6912	—	3.2	6	9	12	0.2	7.6	8.7	TAF 91612	
	LRT 6916	—	4.3	6	9	16	0.2	7.6	8.7	TAF 91616	
	LRT 61010	—	3.9	6	10	10	0.3	8	9.7	RNAF 101710	
7	LRT 7910	—	1.9	7	9	10	0.15	8.2	8.7	RNA 497	
	LRT 71012	—	3.6	7	10	12	0.2	8.6	9.7	TAF 101712	
	LRT 71012-1	—	3.6	7	10	12	0.3	9	9.7	RNAF 102012	
	LRT 71016	—	4.9	7	10	16	0.2	8.6	9.7	TAF 101716 NAX 1023	
8	LRT 81011	—	2.4	8	10	11	0.2	9.6	9.9	RNA 498	
9	LRT 91211	—	3.1	9	12	11	0.3	11	11.5	RNA 499	
	LRT 91212	—	4.5	9	12	12	0.3	11	11.5	TAF 121912 RNAF 122212	
	LRT 91216	—	6	9	12	16	0.3	11	11.5	TAF 121916 NAX 1223	
10	LRT 101412	—	7	10	14	12	0.3	12	13	RNAF 142612	
	LRT 101413	—	7.5	10	14	13	0.3	12	13	RNA 4900 RNAF 142213	
	—	LRTZ 101414	8.2	10	14	14	0.3	12	13	RNA 4900 UU	
	LRT 101416	—	9	10	14	16	0.3	12	13	TAF 142216	
	LRT 101420	—	11.5	10	14	20	0.3	12	13	TAF 142220 RNAFW142220	
12	LRT 121516	—	8	12	15	16.5	0.3	14	14.5	NAX 1523 NBX 1523	
	LRT 121612	—	8.5	12	16	12	0.3	14	15	RNAF 162812	
	LRT 121613	—	8.5	12	16	13	0.3	14	15	RNA 4901 RNAF 162413	
	—	LRTZ 121614	9.6	12	16	14	0.3	14	15	RNA 4901 UU	
	LRT 121616	—	10.5	12	16	16	0.3	14	15	TAF 162416	
	LRT 121620	—	13.5	12	16	20	0.3	14	15	TAF 162420 RNAFW162420	

Note⁽¹⁾ Minimum allowable value of chamfer dimension r
Remark No oil hole is provided.

Shaft dia. mm	Identification number		Mass (Ref.) g	Boundary dimensions mm				Standard mounting dimension mm		Assembled bearings	
				d	F	B	r _{s min} ⁽¹⁾	d _a Min.	d _a Max.		
12	LRT 121622	—	14.5	12	16	22	0.3	14	15	RNA 6901	
	—	LRTZ 121623	15.5	12	16	23	0.3	14	15	RNA 6901 UU	
14	LRT 141717	—	9.5	14	17	17	0.3	16	16.5	NAX 1725 NBX 1725	
15	LRT 151916	—	12.5	15	19	16	0.3	17	18	TAF 192716	
	LRT 151920	—	16	15	19	20	0.3	17	18	TAF 192720	
	LRT 152012	—	12	15	20	12	0.3	17	19	RNAF 203212	
	LRT 152013	—	13.5	15	20	13	0.3	17	19	RNA 4902 RNAF 202813	
	—	LRTZ 152014	14.5	15	20	14	0.3	17	19	RNA 4902 UU	
	LRT 152020	—	21.5	15	20	20.5	0.3	17	19	TR 203320	
	—	LRTZ 152020	21.5	15	20	20.5	0.3	17	19	GTR 203320	
	LRT 152023	—	24	15	20	23	0.3	17	19	RNA 6902	
—	LRTZ 152024	25	15	20	24	0.3	17	19	RNA 6902 UU		
—	LRT 152026	—	28	15	20	26	0.3	17	19	RNAFW 202826	
17	LRT 172020	—	13.5	17	20	20.5	0.3	19	19.5	NAX 2030 NBX 2030	
	LRT 172116	—	14.5	17	21	16	0.3	19	20	TAF 212916	
	LRT 172120	—	18	17	21	20	0.3	19	20	TAF 212920	
	LRT 172213	—	15.5	17	22	13	0.3	19	21	RNA 4903 RNAF 223013	
	—	LRTZ 172214	16.5	17	22	14	0.3	19	21	RNA 4903 UU	
	LRT 172216	—	19	17	22	16	0.3	19	21	RNAF 223516	
	LRT 172223	—	26.5	17	22	23	0.3	19	21	RNA 6903	
	—	LRTZ 172224	28	17	22	24	0.3	19	21	RNA 6903 UU	
	LRT 172225	—	30	17	22	25.5	0.3	19	21	TR 223425	
	—	LRTZ 172225	30	17	22	25.5	0.3	19	21	GTR 223425	
LRT 172226	—	31	17	22	26	0.3	19	21	RNAFW 223026		
LRT 172232	—	38	17	22	32	0.3	19	21	RNAFW 223532		
20	LRT 202416	—	16.5	20	24	16	0.3	22	23	TAF 243216	
	LRT 202420	—	20.5	20	24	20	0.3	22	23	TAF 243220	

Note⁽¹⁾ Minimum allowable value of chamfer dimension r
Remark No oil hole is provided.

INNER RINGS

Inner Rings for General Usage



Shaft dia. 20 – 32mm

Shaft dia. mm	Identification number		Mass (Ref.) g	Boundary dimensions mm				Standard mounting dimension mm		Assembled bearings
				<i>d</i>	<i>F</i>	<i>B</i>	<i>r_{s min}</i> ⁽¹⁾	<i>d_a</i> Min.	<i>d_a</i> Max.	
20	LRT 202516	—	22	20	25	16	0.3	22	24	RNAF 253716
	LRT 202517	—	23	20	25	17	0.3	22	24	RNA 4904 RNAF 253517
	—	LRTZ 202518	24	20	25	18	0.3	22	24	RNA 4904 UU
	LRT 202520	—	28	20	25	20.5	0.3	22	24	TR 253820 NAX 2530 NBX 2530
	—	LRTZ 202520	28	20	25	20.5	0.3	22	24	GTR 253820
	LRT 202525	—	35	20	25	25.5	0.3	22	24	TR 253825
	—	LRTZ 202525	35	20	25	25.5	0.3	22	24	GTR 253825
	LRT 202526	—	36	20	25	26	0.3	22	24	RNAFW 253526
	LRT 202530	—	40.5	20	25	30	0.3	22	24	RNA 6904
	—	LRTZ 202531	41.5	20	25	31	0.3	22	24	RNA 6904 UU
LRT 202532	—	44	20	25	32	0.3	22	24	RNAFW 253732	
22	LRT 222616	—	17.5	22	26	16	0.3	24	25	TAF 263416
	LRT 222620	—	24	22	26	20	0.3	24	25	TAF 263420
	LRT 222817	—	30.5	22	28	17	0.3	24	27	RNA 49/22
	—	LRTZ 222818	32	22	28	18	0.3	24	27	RNA 49/22 UU
	LRT 222830	—	55	22	28	30	0.3	24	27	RNA 69/22
—	LRTZ 222831	55	22	28	31	0.3	24	27	RNA 69/22 UU	
25	LRT 252920	—	25	25	29	20	0.3	27	28	TAF 293820
	LRT 252930	—	38	25	29	30	0.3	27	28	TAF 293830
	LRT 253016	—	28	25	30	16	0.3	27	29	RNAF 304216
	LRT 253017	—	28.5	25	30	17	0.3	27	29	RNA 4905 RNAF 304017
	—	LRTZ 253018	29.5	25	30	18	0.3	27	29	RNA 4905 UU
	LRT 253020	—	34	25	30	20.5	0.3	27	29	NAX 3030 NBX 3030
	LRT 253025	—	42	25	30	25.5	0.3	27	29	TR 304425
	—	LRTZ 253025	42	25	30	25.5	0.3	27	29	GTR 304425
	LRT 253026	—	44.5	25	30	26	0.3	27	29	RNAFW 304026
	LRT 253030	—	49	25	30	30	0.3	27	29	RNA 6905

Note⁽¹⁾ Minimum allowable value of chamfer dimension *r*
 Remark No oil hole is provided.

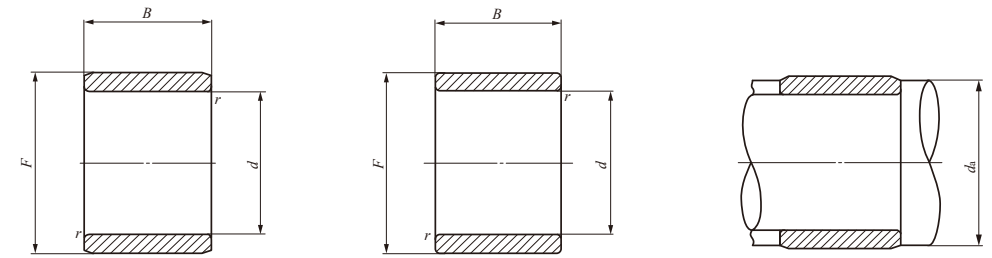

LRT

LRTZ

Shaft dia. mm	Identification number		Mass (Ref.) g	Boundary dimensions mm				Standard mounting dimension mm		Assembled bearings
				<i>d</i>	<i>F</i>	<i>B</i>	<i>r_{s min}</i> ⁽¹⁾	<i>d_a</i> Min.	<i>d_a</i> Max.	
25	—	LRTZ 253031	51	25	30	31	0.3	27	29	RNA 6905 UU
	LRT 253032	—	54	25	30	32	0.3	27	29	RNAFW 304232
28	LRT 283217	—	24.5	28	32	17	0.3	30	31	RNA 49/28
	—	LRTZ 283218	25.5	28	32	18	0.3	30	31	RNA 49/28 UU
	LRT 283220	—	28.5	28	32	20	0.3	30	31	TAF 324220
	LRT 283230	—	43	28	32	30	0.3	30	31	RNA 69/28 TAF 324230
	—	LRTZ 283230	43	28	32	30.5	0.3	30	31	GTR 324530
—	LRTZ 283231	44	28	32	31	0.3	30	31	RNA 69/28 UU	
30	LRT 303516	—	31.5	30	35	16	0.3	32	34	RNAF 354716
	LRT 303517	—	33.5	30	35	17	0.3	32	34	RNA 4906 RNAF 354517
	—	LRTZ 303518	35	30	35	18	0.3	32	34	RNA 4906 UU
	LRT 303520	—	38.5	30	35	20	0.3	32	34	TAF 354520 NAX 3530 NBX 3530
	LRT 303526	—	52	30	35	26	0.3	32	34	RNAFW 354526
	LRT 303530	—	59	30	35	30	0.3	32	34	RNA 6906 TAF 354530
	LRT 303530-1	—	59	30	35	30.5	0.3	32	34	TR 354830
	—	LRTZ 303530	59	30	35	30.5	0.3	32	34	GTR 354830
	—	LRTZ 303531	61	30	35	31	0.3	32	34	RNA 6906 UU
	LRT 303532	—	64	30	35	32	0.3	32	34	RNAFW 354732
32	LRT 323720	—	43.5	32	37	20	0.3	34	36	TAF 374720
	LRT 323730	—	63	32	37	30	0.3	34	36	TAF 374730
	LRT 323830	—	77	32	38	30.5	0.6	36	37	TR 385230
	—	LRTZ 323830	77	32	38	30.5	0.6	36	37	GTR 385230
	LRT 324020	—	69	32	40	20	0.6	36	39	RNA 49/32
	—	LRTZ 324021	72.5	32	40	21	0.6	36	39	RNA 49/32 UU
	LRT 324036	—	123	32	40	36	0.6	36	39	RNA 69/32
	—	LRTZ 324037	130	32	40	37	0.6	36	39	RNA 69/32 UU

Note⁽¹⁾ Minimum allowable value of chamfer dimension *r*
 Remark No oil hole is provided.

Inner Rings for General Usage



Shaft dia. 35 – 50mm

Shaft dia. mm	Identification number		Mass (Ref.) g	Boundary dimensions mm				Standard mounting dimension mm		Assembled bearings
				<i>d</i>	<i>F</i>	<i>B</i>	<i>r_{s min}</i> ⁽¹⁾	Min.	Max.	
35	LRT 354017	—	39	35	40	17	0.3	37	39	RNAF 405017
	LRT 354020	—	46	35	40	20	0.3	37	39	TAF 405020 RNAF 405520 NAX 4032 NBX 4032
	—	LRTZ 354020	46	35	40	20.5	0.6	39	39.5	GTR 405520
	LRT 354030	—	67	35	40	30	0.3	37	39	TAF 405030
	LRT 354034	—	78	35	40	34	0.3	37	39	RNAFW 405034
	LRT 354040	—	95	35	40	40	0.3	37	39	RNAFW 405540
	LRT 354220	—	65	35	42	20	0.6	39	41	RNA 4907
	—	LRTZ 354221	67	35	42	21	0.6	39	41	RNA 4907 UU
	LRT 354230	—	97	35	42	30.5	0.6	39	41	TR 425630
	—	LRTZ 354230	100	35	42	30.5	0.6	39	41	GTR 425630
38	LRT 384320	—	47.5	38	43	20	0.3	40	42	RNA 6907
	LRT 384330	—	72	38	43	30	0.3	40	42	RNA 6907 UU
	LRT 384320	—	47.5	38	43	20	0.3	40	42	TAF 435320
40	LRT 404517	—	44.5	40	45	17	0.3	42	44	TAF 435330
	LRT 404520	—	51	40	45	20	0.3	42	44	RNAF 455517
	LRT 404530	—	77	40	45	30	0.3	42	44	TAF 455520 RNAF 456220 NAX 4532 NBX 4532
	LRT 404530-1	—	77	40	45	30.5	0.6	44	44.5	TAF 455530
	—	LRTZ 404530	77	40	45	30.5	0.6	44	44.5	TR 455930
	LRT 404534	—	88	40	45	34	0.3	42	44	GTR 455930
	LRT 404540	—	105	40	45	40	0.3	42	44	RNAFW 455534
	LRT 404822	—	93	40	48	22	0.6	44	47	RNAFW 456240
	—	LRTZ 404823	95	40	48	23	0.6	44	47	RNA 4908
	LRT 404840	—	165	40	48	40	0.6	44	47	RNA 4908 UU
—	LRTZ 404841	170	40	48	41	0.6	44	47	RNA 6908	
—	—	—	—	—	—	—	—	—	—	RNA 6908 UU

Note⁽¹⁾ Minimum allowable value of chamfer dimension *r*
 Remark No oil hole is provided.

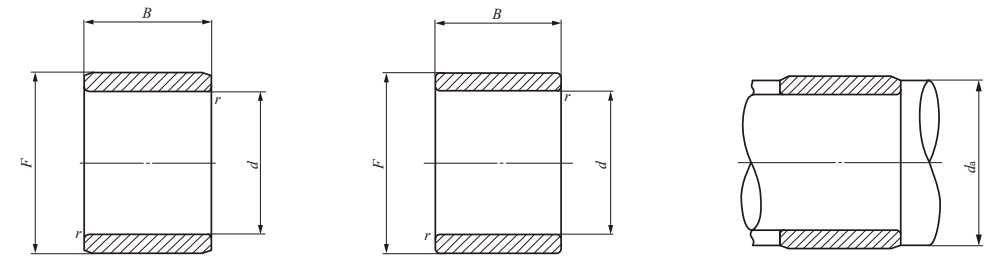

LRT

LRTZ

Shaft dia. mm	Identification number		Mass (Ref.) g	Boundary dimensions mm				Standard mounting dimension mm		Assembled bearings
				<i>d</i>	<i>F</i>	<i>B</i>	<i>r_{s min}</i> ⁽¹⁾	Min.	Max.	
42	LRT 424720	—	54	42	47	20	0.3	44	46	TAF 475720
	LRT 424730	—	81	42	47	30	0.3	44	46	TAF 475730
	LRT 424830	—	100	42	48	30.5	0.6	46	47	TR 486230
	—	LRTZ 424830	100	42	48	30.5	0.6	46	47	GTR 486230
45	LRT 455020	—	58	45	50	20	0.3	47	49	RNAF 506220
	LRT 455025	—	71	45	50	25	0.3	47	49	TAF 506225 RNAF 506225 NBX 5035
	LRT 455030	—	90	45	50	30.5	0.6	49	49.5	TR 506430
	—	LRTZ 455030	90	45	50	30.5	0.6	49	49.5	GTR 506430
	LRT 455035	—	95	45	50	35	0.3	47	49	TAF 506235
	LRT 455040	—	115	45	50	40	0.3	47	49	RNAFW 506240
	LRT 455222	—	88	45	52	22	0.6	49	51	RNA 4909
	—	LRTZ 455223	93	45	52	23	0.6	49	51	RNA 4909 UU
	LRT 455240	—	165	45	52	40	0.6	49	51	RNA 6909
	—	LRTZ 455241	170	45	52	41	0.6	49	51	RNA 6909 UU
50	LRT 455520	—	120	45	55	20	1	50	54	RNAF 557220
	LRT 455540	—	245	45	55	40	1	50	54	RNAFW 557240
	LRT 505520	—	63	50	55	20	0.3	52	54	RNAF 556820
	LRT 505525	—	77	50	55	25	0.3	52	54	TAF 556825
	LRT 505535	—	110	50	55	35	0.3	52	54	TAF 556835
	LRT 505540	—	130	50	55	40	0.3	52	54	RNAFW 556840
	LRT 505822	—	116	50	58	22	0.6	54	57	RNA 4910
	—	LRTZ 505823	118	50	58	23	0.6	54	57	RNA 4910 UU
	LRT 505840	—	210	50	58	40	0.6	54	57	RNA 6910
	—	LRTZ 505841	215	50	58	41	0.6	54	57	RNA 6910 UU
LRT 505845	—	235	50	58	45.5	1	55	57	TR 587745	
—	LRTZ 505845	235	50	58	45.5	1	55	57	GTR 587745	
LRT 506020	—	135	50	60	20	1	55	59	RNAF 607820	

Note⁽¹⁾ Minimum allowable value of chamfer dimension *r*
 Remark No oil hole is provided.

INNER RINGS

Inner Rings for General Usage



Shaft dia. 50 – 80mm

Shaft dia. mm	Identification number	Mass (Ref.) g	Boundary dimensions mm					Standard mounting dimension mm		Assembled bearings
			<i>d</i>	<i>F</i>	<i>B</i>	<i>r_{s min}</i> ⁽¹⁾	Min.	Max.	<i>d_a</i>	
50	LRT 506025	165	50	60	25.5	1	55	59	NAX 6040 NBX 6040 RNAFW 607840	
	LRT 506040	265	50	60	40	1	55	59		
55	LRT 556025	88	55	60	25	0.3	57	59	TAF 607225	
	LRT 556035	120	55	60	35	0.3	57	59	TAF 607235	
	LRT 556238	190	55	62	38.5	1	60	60.5	TR 628138	
	—	LRTZ 556238	190	55	62	38.5	1	60	60.5	GTR 628138
	LRT 556325	145	55	63	25	1	60	61	RNA 4911	
	—	LRTZ 556326	150	55	63	26	1	60	61	RNA 4911 UU
	LRT 556345	255	55	63	45	1	60	61	RNA 6911	
	—	LRTZ 556346	260	55	63	46	1	60	61	RNA 6911 UU
60	LRT 556530	220	55	65	30	1.5	63	63.5	RNAF 658530	
	LRT 556560	435	55	65	60	1.5	63	63.5	RNAFW 658560	
60	LRT 606825	150	60	68	25	0.6	64	66	TAF 688225	
	LRT 606825-1	150	60	68	25	1	65	66	RNA 4912	
	—	LRTZ 606826	160	60	68	26	1	65	66	RNA 4912 UU
	LRT 606835	210	60	68	35	0.6	64	66	TAF 688235	
	LRT 606845	275	60	68	45	1	65	66	RNA 6912	
	—	LRTZ 606846	280	60	68	46	1	65	66	RNA 6912 UU
	LRT 607025	195	60	70	25.5	1	65	68	NAX 7040	
	LRT 607030	240	60	70	30	1.5	68	68.5	RNAF 709030	
	LRT 607045	355	60	70	45.5	1	65	68	TR 708945	
	—	LRTZ 607045	360	60	70	45.5	1	65	68	GTR 708945
LRT 607060	480	60	70	60	1.5	68	68.5	RNAFW 709060		
65	LRT 657225	145	65	72	25	1	70	70.5	RNA 4913	
	—	LRTZ 657226	150	65	72	26	1	70	70.5	RNA 4913 UU
	LRT 657245	255	65	72	45	1	70	70.5	RNA 6913	
	—	LRTZ 657246	265	65	72	46	1	70	70.5	RNA 6913 UU
	LRT 657335	235	65	73	35	1	70	71	TAF 739035	

Note⁽¹⁾ Minimum allowable value of chamfer dimension *r*
Remark No oil hole is provided.

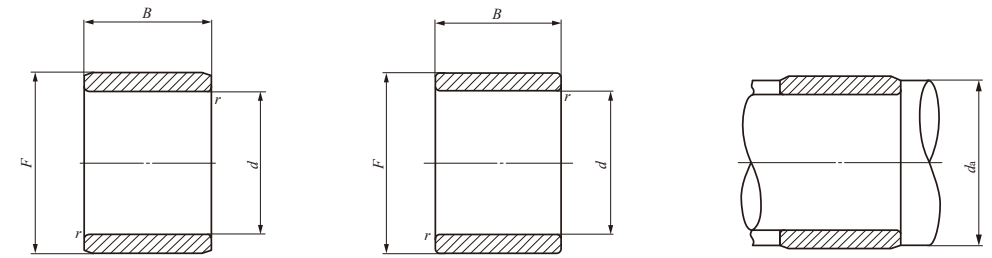

LRT

LRTZ

Shaft dia. mm	Identification number	Mass (Ref.) g	Boundary dimensions mm					Standard mounting dimension mm		Assembled bearings
			<i>d</i>	<i>F</i>	<i>B</i>	<i>r_{s min}</i> ⁽¹⁾	Min.	Max.	<i>d_a</i>	
65	LRT 657530	260	65	75	30	1.5	73	73.5	RNAF 759530 RNAFW 759560	
	LRT 657560	520	65	75	60	1.5	73	73.5		
70	LRT 708025	225	70	80	25	1	75	78	TAF 809525	
	LRT 708030	275	70	80	30	1	75	78	RNA 4914	
	LRT 708030-1	275	70	80	30	1.5	78	78.5	RNAF 8010030	
	—	LRTZ 708031	275	70	80	31	1	75	78	RNA 4914 UU
	LRT 708035	310	70	80	35	1	75	78	TAF 809535	
	LRT 708054	490	70	80	54	1	75	78	RNA 6914	
	—	LRTZ 708055	500	70	80	55	1	75	78	RNA 6914 UU
LRT 708060	560	70	80	60	1.5	78	78.5	RNAFW 8010060		
75	LRT 758345	350	75	83	45.5	1	80	81	TR 8310845	
	—	LRTZ 758345	350	75	83	45.5	1	80	81	GTR 8310845
	LRT 758525	240	75	85	25	1	80	83	TAF 8510525	
	LRT 758530	290	75	85	30	1	80	83	RNA 4915	
	LRT 758530-1	290	75	85	30	1.5	83	83.5	RNAF 8510530	
	—	LRTZ 758531	300	75	85	31	1	80	83	RNA 4915 UU
	LRT 758535	335	75	85	35	1	80	83	TAF 8510535	
	LRT 758554	520	75	85	54	1	80	83	RNA 6915	
—	LRTZ 758555	530	75	85	55	1	80	83	RNA 6915 UU	
80	LRT 809025	255	80	90	25	1	85	88	TAF 9011025	
	LRT 809030	310	80	90	30	1	85	88	RNA 4916	
	LRT 809030-1	310	80	90	30	1.5	88	88.5	RNAF 9011030	
	—	LRTZ 809031	315	80	90	31	1	85	88	RNA 4916 UU
	LRT 809035	355	80	90	35	1	85	88	TAF 9011035	
	LRT 809054	550	80	90	54	1	85	88	RNA 6916	
—	LRTZ 809055	560	80	90	55	1	85	88	RNA 6916 UU	

Note⁽¹⁾ Minimum allowable value of chamfer dimension *r*
Remark No oil hole is provided.

H

IRT
IRB
LRT
LRB

INNER RINGS

Inner Rings for General Usage

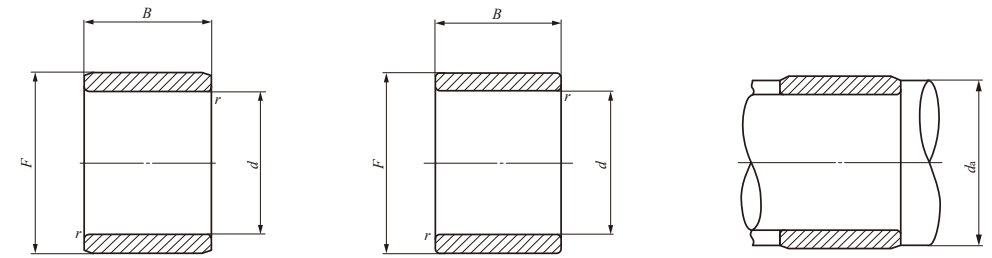

LRT

LRTZ

Shaft dia. 85 – 140mm

Shaft dia. mm	Identification number		Mass (Ref.) g	Boundary dimensions mm				Standard mounting dimension mm		Assembled bearings
				<i>d</i>	<i>F</i>	<i>B</i>	<i>r_{s min}</i> ⁽¹⁾	Min.	Max.	
85	LRT 859350	—	440	85	93	50.5	1	90	91	TR 9311850
	—	LRTZ 859350	440	85	93	50.5	1	90	91	GTR 9311850
	LRT 859526	—	280	85	95	26	1	90	93	TAF 9511526
	LRT 859530	—	330	85	95	30	1.5	93	93.5	RNAF 9511530
	LRT 859536	—	390	85	95	36	1	90	93	TAF 9511536
	LRT 859545	—	490	85	95	45.5	1.5	93	93.5	TR 9512045
	—	LRTZ 859545	490	85	95	45.5	1.5	93	93.5	GTR 9512045
	LRT 8510035	—	575	85	100	35	1.1	91.5	98	RNA 4917
	—	LRTZ 8510036	605	85	100	36	1.1	91.5	98	RNA 4917 UU
	LRT 8510063	—	1 040	85	100	63	1.1	91.5	98	RNA 6917
—	LRTZ 8510064	1 060	85	100	64	1.1	91.5	98	RNA 6917 UU	
90	LRT 9010026	—	295	90	100	26	1	95	98	TAF 10012026
	LRT 9010030	—	355	90	100	30	1.5	98	98.5	RNAF 10012030
	LRT 9010036	—	415	90	100	36	1	95	98	TAF 10012036
	LRT 9010050	—	580	90	100	50.5	1.5	98	98.5	TR 10012550
	—	LRTZ 9010050	580	90	100	50.5	1.5	98	98.5	GTR 10012550
	LRT 9010535	—	610	90	105	35	1.1	96.5	103	RNA 4918
	—	LRTZ 9010536	630	90	105	36	1.1	96.5	103	RNA 4918 UU
	LRT 9010563	—	1 100	90	105	63	1.1	96.5	103	RNA 6918
—	LRTZ 9010564	1 120	90	105	64	1.1	96.5	103	RNA 6918 UU	
95	LRT 9510526	—	315	95	105	26	1	100	103	TAF 10512526
	LRT 9510536	—	430	95	105	36	1	100	103	TAF 10512536
	LRT 9511035	—	650	95	110	35	1.1	101.5	108	RNA 4919
	—	LRTZ 9511036	660	95	110	36	1.1	101.5	108	RNA 4919 UU
	LRT 9511063	—	1 160	95	110	63	1.1	101.5	108	RNA 6919
	—	LRTZ 9511064	1 180	95	110	64	1.1	101.5	108	RNA 6919 UU

Note⁽¹⁾ Minimum allowable value of chamfer dimension *r*
 Remark No oil hole is provided.

Shaft dia. mm	Identification number		Mass (Ref.) g	Boundary dimensions mm				Standard mounting dimension mm		Assembled bearings
				<i>d</i>	<i>F</i>	<i>B</i>	<i>r_{s min}</i> ⁽¹⁾	Min.	Max.	
100	LRT 10011030	—	380	100	110	30	1	105	108	TAF 11013030
	LRT 10011040	—	500	100	110	40	1	105	108	TAF 11013040
	LRT 10011050	—	640	100	110	50.5	1.5	108	108.5	TR 11013550
	—	LRTZ 10011050	640	100	110	50.5	1.5	108	108.5	GTR 11013550
	LRT 10011540	—	770	100	115	40	1.1	106.5	113	RNA 4920
	—	LRTZ 10011541	780	100	115	41	1.1	106.5	113	RNA 4920 UU
105	LRT 10511550	—	670	105	115	50.5	1.5	113	113.5	TR 11515350
	—	LRTZ 10511550	670	105	115	50.5	1.5	113	113.5	GTR 11515350
110	LRT 11012030	—	410	110	120	30	1	115	118	RNA 4822
	LRT 11012540	—	840	110	125	40	1.1	116.5	123	RNA 4922
	—	LRTZ 11012541	870	110	125	41	1.1	116.5	123	RNA 4922 UU
120	LRT 12013030	—	450	120	130	30	1	125	128	RNA 4824
	LRT 12013545	—	1 030	120	135	45	1.1	126.5	133	RNA 4924
	—	LRTZ 12013546	1 050	120	135	46	1.1	126.5	133	RNA 4924 UU
125	LRT 12514060	—	1 460	125	140	60.5	1.5	133	138	TR 14017860
	—	LRTZ 12514060	1 460	125	140	60.5	1.5	133	138	GTR 14017860
130	LRT 13014535	—	860	130	145	35	1.1	136.5	143	RNA 4826
	LRT 13015050	—	1 670	130	150	50	1.5	138	148	RNA 4926
	—	LRTZ 13015051	1 720	130	150	51	1.5	138	148	RNA 4926 UU
135	LRT 13515060	—	1 560	135	150	60.5	1.5	143	148	TR 15018860
	—	LRTZ 13515060	1 560	135	150	60.5	1.5	143	148	GTR 15018860
140	LRT 14015535	—	930	140	155	35	1.1	146.5	153	RNA 4828
	LRT 14016050	—	1 790	140	160	50	1.5	148	158	RNA 4928
	—	LRTZ 14016051	1 830	140	160	51	1.5	148	158	RNA 4928 UU

Note⁽¹⁾ Minimum allowable value of chamfer dimension *r*
 Remark No oil hole is provided.

H

IRT
IRB
LRT
LRB

INNER RINGS

Inner Rings for General Usage

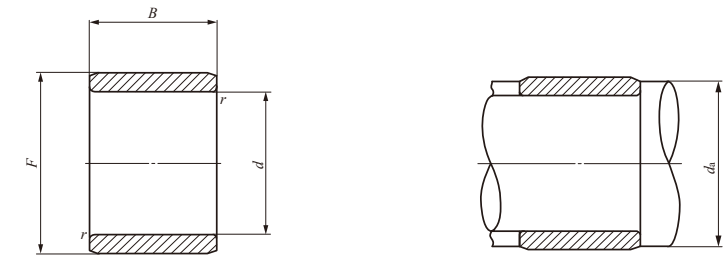

LRT

Shaft dia. 150 – 440mm

Shaft dia. mm	Identification number	Mass (Ref.) g	Boundary dimensions mm				Standard mounting dimension mm		Assembled bearings
			d	F	B	⁽¹⁾ r _{s min}	Min.	Max.	
150	LRT 15016540	1 130	150	165	40	1.1	156.5	163	RNA 4830
	LRT 15017060	2 290	150	170	60	2	159	168	RNA 4930
160	LRT 16017540	1 200	160	175	40	1.1	166.5	173	RNA 4832
	LRT 16018060	2 440	160	180	60	2	169	178	RNA 4932
170	LRT 17018545	1 420	170	185	45	1.1	176.5	183	RNA 4834
	LRT 17019060	2 580	170	190	60	2	179	188	RNA 4934
180	LRT 18019545	1 500	180	195	45	1.1	186.5	193	RNA 4836
	LRT 18020569	3 950	180	205	69	2	189	203	RNA 4936
190	LRT 19021050	2 380	190	210	50	1.5	198	208	RNA 4838
	LRT 19021569	4 200	190	215	69	2	199	213	RNA 4938
200	LRT 20022050	2 520	200	220	50	1.5	208	218	RNA 4840
	LRT 20022580	5 000	200	225	80	2.1	211	223	RNA 4940
220	LRT 22024050	2 750	220	240	50	1.5	228	238	RNA 4844
	LRT 22024580	5 500	220	245	80	2.1	231	243	RNA 4944
240	LRT 24026560	4 530	240	265	60	2	249	262	RNA 4848
	LRT 24026580	6 000	240	265	80	2.1	251	262	RNA 4948
260	LRT 26028560	4 930	260	285	60	2	269	282	RNA 4852
	LRT 260290100	9 900	260	290	100	2.1	271	287	RNA 4952
280	LRT 28030569	6 050	280	305	69	2	289	302	RNA 4856
	LRT 280310100	10 600	280	310	100	2.1	291	307	RNA 4956
300	LRT 30033080	9 100	300	330	80	2.1	311	327	RNA 4860
	LRT 300340118	18 000	300	340	118	3	313	337	RNA 4960
320	LRT 32035080	9 600	320	350	80	2.1	331	347	RNA 4864
	LRT 320360118	19 200	320	360	118	3	333	357	RNA 4964

Note⁽¹⁾ Minimum allowable value of chamfer dimension *r*
 Remark No oil hole is provided.

Shaft dia. mm	Identification number	Mass (Ref.) g	Boundary dimensions mm				Standard mounting dimension mm		Assembled bearings
			d	F	B	⁽¹⁾ r _{s min}	Min.	Max.	
340	LRT 34037080	10 200	340	370	80	2.1	351	367	RNA 4868
	LRT 340380118	20 300	340	380	118	3	353	377	RNA 4968
360	LRT 36039080	10 800	360	390	80	2.1	371	387	RNA 4872
	LRT 360400118	21 500	360	400	118	3	373	397	RNA 4972
380	LRT 380415100	16 700	380	415	100	2.1	391	412	RNA 4876
	LRT 380430140	33 900	380	430	140	4	396	427	RNA 4976
400	LRT 400450140	35 600	400	450	140	4	416	447	RNA 4980
420	LRT 420470140	37 300	420	470	140	4	436	467	RNA 4984
440	LRT 440490160	44 100	440	490	160	4	456	487	RNA 4988

Note⁽¹⁾ Minimum allowable value of chamfer dimension *r*
 Remark No oil hole is provided.

H

IRT
IRB
LRT
LRB

INNER RINGS

Inner Rings for General Usage **Inch Series**



Shaft dia. 9.525 – 22.225mm

Shaft dia. mm (inch)	Identification number		Mass (Ref.) g	Boundary dimensions mm(inch)			Standard mounting dimensions mm ⁽¹⁾		
				<i>d</i>	<i>F</i>	<i>B</i>	<i>d_a</i>		<i>r_{as} max</i>
							Min.	Max.	Max.
9.525 (³ / ₈)	LRB 61012	—	18.5	9.525 (³ / ₈)	15.875 (⁵ / ₈)	19.300	14	14.5	0.6
	—	LRBZ 61016 B	25	9.525 (³ / ₈)	15.875 (⁵ / ₈)	25.650	14	14.5	0.6
12.700 (¹ / ₂)	LRB 81212	—	23.5	12.700 (¹ / ₂)	19.050 (³ / ₄)	19.300	17.5	18	1
	LRB 81216	—	31	12.700 (¹ / ₂)	19.050 (³ / ₄)	25.650	17.5	18	1
	—	LRBZ 81216 B	31	12.700 (¹ / ₂)	19.050 (³ / ₄)	25.650	17.5	18	0.6
15.875 (⁵ / ₈)	LRB 101412	—	28	15.875 (⁵ / ₈)	22.225 (⁷ / ₈)	19.300	21	21.2	1
	LRB 101416	—	37.5	15.875 (⁵ / ₈)	22.225 (⁷ / ₈)	25.650	21	21.2	1
	—	LRBZ 101416 B	37.5	15.875 (⁵ / ₈)	22.225 (⁷ / ₈)	25.650	21	21.2	0.6
19.050 (³ / ₄)	LRB 121612	—	33	19.050 (³ / ₄)	25.400 (1)	19.300	24	24.4	1
	LRB 121616	—	44	19.050 (³ / ₄)	25.400 (1)	25.650	24	24.4	1
	—	LRBZ 121616 B	44	19.050 (³ / ₄)	25.400 (1)	25.650	24	24.4	0.6
22.225 (⁷ / ₈)	LRB 141816	—	50	22.225 (⁷ / ₈)	28.575 (1 ¹ / ₈)	25.650	27	27.5	1
	LRB 141820	—	62	22.225 (⁷ / ₈)	28.575 (1 ¹ / ₈)	32.000	27	27.5	1
	—	LRBZ 141820 B	62	22.225 (⁷ / ₈)	28.575 (1 ¹ / ₈)	32.000	27	27.5	0.6

Note(1) Maximum allowable fillet corner radius of shaft
 Remark LRB and LRBZ...B are provided with an oil groove and an oil hole.

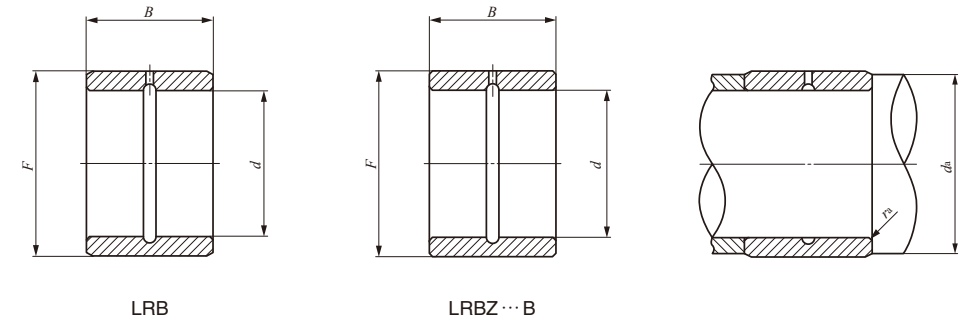

Assembled bearings	
BR 101812	BR 101816UU
BR 122012	BR 122016
BR 122016	BR 122016UU
BR 142212	BR 142216
BR 142216	BR 142216UU
BR 162412	BR 162416
BR 162416	BR 162416UU

- BR 182616**
- BR 182620**
- BR 182620UU**

H
 IRT
 IRB
 LRT
 LRB

INNER RINGS

Inner Rings for General Usage Inch Series

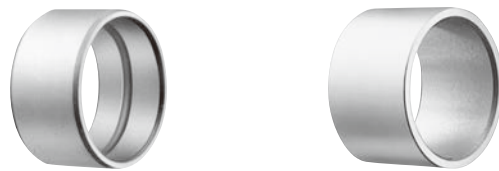

Shaft dia. 25.400 – 38.100mm

Shaft dia. mm (inch)	Identification number		Mass (Ref.) g	Boundary dimensions mm(inch)			Standard mounting dimensions mm ⁽¹⁾		
				<i>d</i>	<i>F</i>	<i>B</i>	<i>d_a</i>		<i>r_{as}</i> max
							Min.	Max.	Max.
25.400 (1)	LRB 162016	—	56	25.400 (1)	31.750 (1 1/4)	25.650	30.5	30.7	1
	LRB 162020	—	72	25.400 (1)	31.750 (1 1/4)	32.000	30.5	30.7	1
	—	LRBZ 162020 B	72	25.400 (1)	31.750 (1 1/4)	32.000	30.5	30.7	0.6
28.575 (1 1/8)	LRB 182216	—	63	28.575 (1 1/8)	34.925 (1 3/8)	25.650	33.5	33.9	1
	LRB 182220	—	77	28.575 (1 1/8)	34.925 (1 3/8)	32.000	33.5	33.9	1
	—	LRBZ 182220 B	77	28.575 (1 1/8)	34.925 (1 3/8)	32.000	33.5	33.9	0.6
31.750 (1 1/4)	LRB 202416	—	71	31.750 (1 1/4)	38.100 (1 1/2)	25.650	37	37.1	1.5
	LRB 202420	—	86	31.750 (1 1/4)	38.100 (1 1/2)	32.000	37	37.1	1.5
	—	LRBZ 202420 B	86	31.750 (1 1/4)	38.100 (1 1/2)	32.000	37	37.1	0.6
34.925 (1 3/8)	LRB 222616	—	77	34.925 (1 3/8)	41.275 (1 5/8)	25.650	40.2	40.2	1.5
	LRB 222620	—	96	34.925 (1 3/8)	41.275 (1 5/8)	32.000	40.2	40.2	1.5
	—	LRBZ 222620 B	96	34.925 (1 3/8)	41.275 (1 5/8)	32.000	40.2	40.2	0.6
38.100 (1 1/2)	LRB 242816	—	80	38.100 (1 1/2)	44.450 (1 3/4)	25.650	43.3	43.4	1.5
	LRB 242820	—	100	38.100 (1 1/2)	44.450 (1 3/4)	32.000	43.3	43.4	1.5
	LRB 243020	—	155	38.100 (1 1/2)	47.625 (1 7/8)	32.000	43.3	45	1.5
	—	LRBZ 242820 B	100	38.100 (1 1/2)	44.450 (1 3/4)	32.000	43.3	43.4	0.6
	—	LRBZ 243020 B	160	38.100 (1 1/2)	47.625 (1 7/8)	32.000	43.3	45	1

Note(1) Maximum allowable fillet corner radius of shaft

Remark LRB and LRBZ···B are provided with an oil groove and an oil hole.

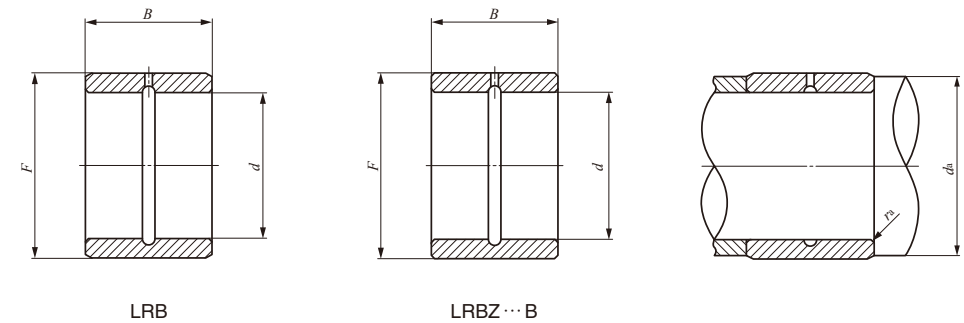

Assembled bearings	
BR 202816	
BR 202820	
BR 202820UU	
BR 223016	
BR 223020	
BR 223020UU	
BR 243316	
BR 243320	
BR 243320UU	
BR 263516	
BR 263520	
BR 263520UU	
BR 283716	
BR 283720	BR 283820
BR 303920	
BR 283720UU	
BR 303920UU	

H

IRT
IRB
LRT
LRB

INNER RINGS

Inner Rings for General Usage **Inch Series**



Shaft dia. 41.275 – 63.500mm

Shaft dia. mm (inch)	Identification number		Mass (Ref.) g	Boundary dimensions mm(inch)			Standard mounting dimensions mm ⁽¹⁾		
				<i>d</i>	<i>F</i>	<i>B</i>	<i>d_a</i>		<i>r_{as max}</i>
						Min.	Max.	Max.	
41.275 (1 5/8)	LRB 263216	—	135	41.275 (1 5/8)	50.800 (2)	25.650	48	49	1.5
	LRB 263220	—	170	41.275 (1 5/8)	50.800 (2)	32.000	48	49	1.5
	—	LRBZ 263220 B	170	41.275 (1 5/8)	50.800 (2)	32.000	48	49	1
44.450 (1 3/4)	LRB 283624	—	300	44.450 (1 3/4)	57.150 (2 1/4)	38.350	52.5	55	1.5
	LRB 283628	—	345	44.450 (1 3/4)	57.150 (2 1/4)	44.700	52.5	55	1.5
	—	LRBZ 283628 B	345	44.450 (1 3/4)	57.150 (2 1/4)	44.700	52.5	55	1.5
50.800 (2)	LRB 324024	—	335	50.800 (2)	63.500 (2 1/2)	38.350	58	61	2
	LRB 324028	—	390	50.800 (2)	63.500 (2 1/2)	44.700	58	61	2
	—	LRBZ 324028 B	390	50.800 (2)	63.500 (2 1/2)	44.700	58	61	1.5
57.150 (2 1/4)	LRB 364424	—	375	57.150 (2 1/4)	69.850 (2 3/4)	38.350	65	67	2
	LRB 364428	—	440	57.150 (2 1/4)	69.850 (2 3/4)	44.700	65	67	2
	—	LRBZ 364428 B	440	57.150 (2 1/4)	69.850 (2 3/4)	44.700	65	67	1.5
63.500 (2 1/2)	LRB 404824	—	410	63.500 (2 1/2)	76.200 (3)	38.350	71	73	2
	LRB 404828	—	480	63.500 (2 1/2)	76.200 (3)	44.700	71	73	2
	—	LRBZ 404828 B	480	63.500 (2 1/2)	76.200 (3)	44.700	71	73	1.5

Note⁽¹⁾ Maximum allowable fillet corner radius of shaft
 Remark LRB and LRBZ...B are provided with an oil groove and an oil hole.

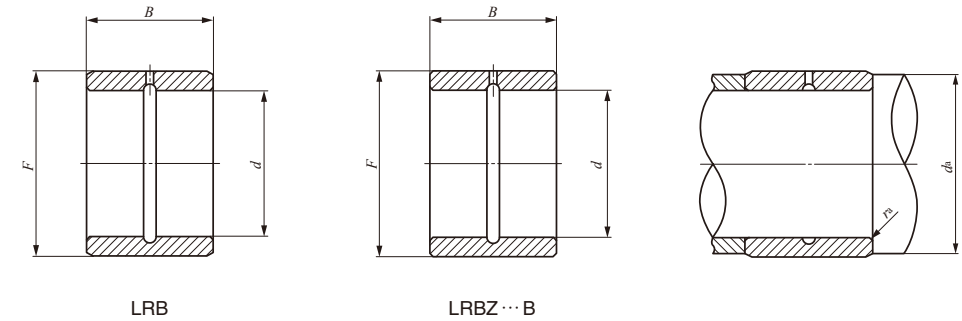

Assembled bearings	
BR 324116	
BR 324120	
BR 324120UU	
BR 364824	
BR 364828	
BR 364828UU	
BR 405224	
BR 405228	
BR 405228UU	
BR 445624	
BR 445628	
BR 445628UU	

BR 486024	
BR 486028	
BR 486028UU	

H
 IRT
 IRB
 LRT
 LRB

INNER RINGS

Inner Rings for General Usage **Inch Series**



Shaft dia. 69.850 — 95.250mm

Shaft dia. mm (inch)	Identification number		Mass (Ref.) g	Boundary dimensions mm(inch)			Standard mounting dimensions mm ⁽¹⁾		
				<i>d</i>	<i>F</i>	<i>B</i>	<i>d_a</i>		<i>r_{as max}</i>
							Min.	Max.	Max.
69.850 (2 3/4)	LRB 445228	—	530	69.850 (2 3/4)	82.550 (3 1/4)	44.700	77	79	2
	LRB 445232	—	600	69.850 (2 3/4)	82.550 (3 1/4)	51.050	77	79	2
	—	LRBZ 445228 B	530	69.850 (2 3/4)	82.550 (3 1/4)	44.700	77	79	1.5
76.200 (3)	LRB 485632	—	640	76.200 (3)	88.900 (3 1/2)	51.050	83.5	86	2
	—	LRBZ 485632 B	640	76.200 (3)	88.900 (3 1/2)	51.050	83.5	86	1.5
82.550 (3 1/4)	LRB 526032	—	690	82.550 (3 1/4)	95.250 (3 3/4)	51.050	91	93	2.5
	—	LRBZ 526032 B	690	82.550 (3 1/4)	95.250 (3 3/4)	51.050	91	93	1.5
88.900 (3 1/2)	LRB 566432	—	750	88.900 (3 1/2)	101.600 (4)	51.050	97	99	2.5

Note(1) Maximum allowable fillet corner radius of shaft

Remark LRB with inner ring bore diameter *d* of 76.200 mm or less and LRBZ...B are provided with an oil groove and an oil hole. Other models are provided with an oil groove and two oil holes.

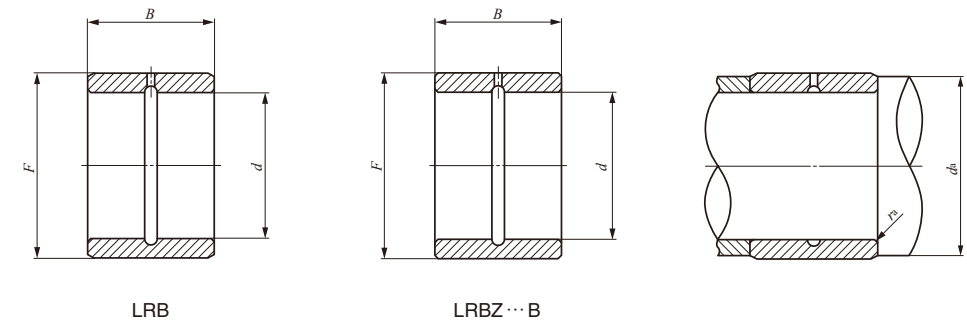

LRB

LRBZ...B

Assembled bearings

- BR 526828
- BR 526832
- BR 526828UU
- BR 567232
- BR 567232UU
- BR 607632
- BR 607632UU
- BR 648032

H

IRT
IRB
LRT
LRB